

# ASSEMBLY

**NOTE:** This Operator's Manual covers several models. Tractor features may vary by model. Not all features in this manual are applicable to all tractor models and the tractor depicted may differ from yours.

**NOTE:** All references in this manual to the left or right side and front or back of the tractor are from the operating position only. Exceptions, if any, will be specified.

## Preparation

### MANUALLY MOVING THE TRACTOR

1. To engage the transmission bypass rods, pull the rod back (a) and into lower section of "J" slot. Repeat on opposite side. See Figure 1.

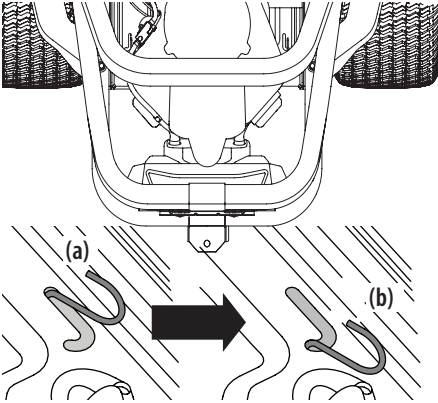

Figure 1

2. After moving tractor, reverse Step 1 to disengage the bypass rods.
3. Remove the deck wash system nozzle adapter from the manual bag, store for future use.

### INSTALL HITCH (IF NECESSARY)

1. Locate Hitch (a) and install on the rear of the frame using the two hex washer screws (b) provided. See Figure 2.

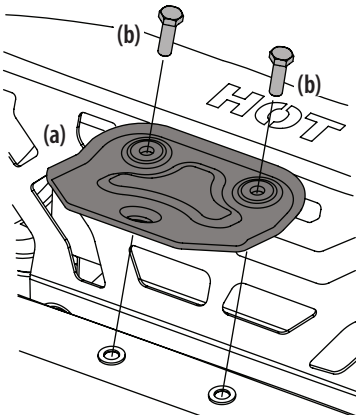

Figure 2

**NOTE:** Hitch and hex washer screws will be in the hardware pack.

### REPOSITION UPPER HOOP (IF NECESSARY)

Upper hoop may be positioned down for shipping purposes:

1. Remove the two hex washer screws (a) partially installed on the frame. See Figure 3.

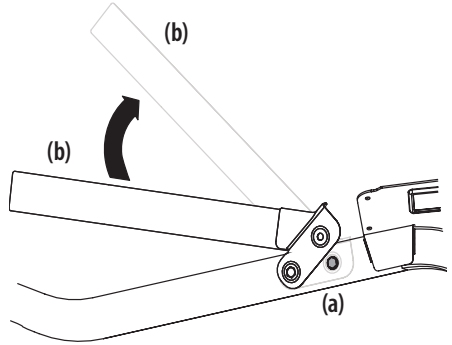

Figure 3

2. Rotate the upper hoop (b) into position. See Figure 3.
3. Secure hoop in place with the hex washer screws removed in Step 1. Torque the hex washer screws to 159-239 in-lbs (18-27 N-m).

## Install Operator's Seat

### KNOB ADJUST OR LEVER ADJUST

1. Cut any straps securing the seat assembly to the tractor. Remove all packing material.

**NOTE:** Be careful not to cut the seat wiring harness.

2. Install the seat onto the seat pan (a) using hardware provided.
  - a. For a Knob Adjust seat insert bolts (b) in the rear holes and lock washer (c) and knobs (d) in the front. Tighten securely. See Figure 4.

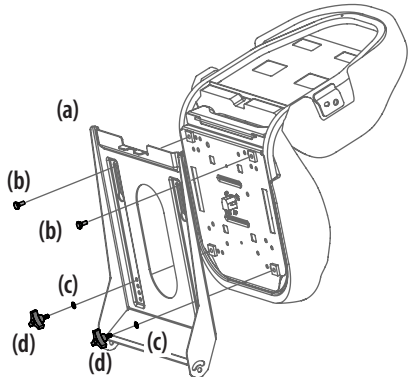

Figure 4

# ASSEMBLY

- b. For a Lever Adjust seat use flange lock nuts (a) and flat washers (b). See Figure 5.

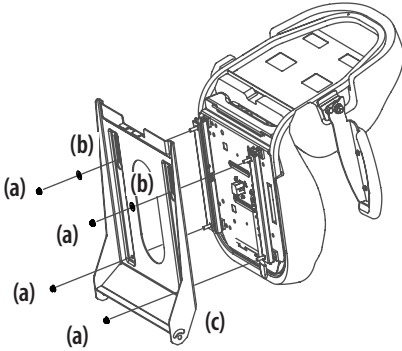

Figure 5

3. If necessary, securely connect the seat switch wiring harness (a) to the seat switch (b). See Figure 6. Secure excess wire away from pinch points before continuing.

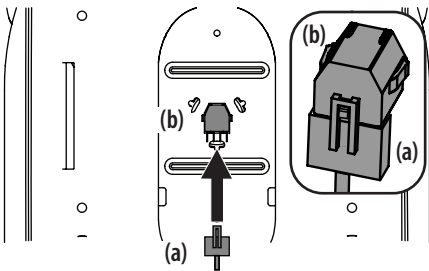

Figure 6

**NOTE:** Tractor will not operate without the seat switch wiring harness connected.

## Position Lapbar Drive Control Levers

The lapbar drive control levers can be adjusted up/down and forward/backward for the operator's comfort. Three height positions are available and/or levers can be rotated forward and rearward using the knob.

To adjust the lapbar drive control lever height, proceed as follows:

1. Remove the two carriage screws (a) and two flange lock nuts (b) that secure the lapbar drive control lever (c) to the upper handle adjuster (d). See Figure 7.

**NOTE:** The multi-tool (if equipped) can be used to make this adjustment.

2. Move the lapbar drive control lever into one of three available heights and secure in place with the carriage screws and flange lock nuts. See Figure 7.

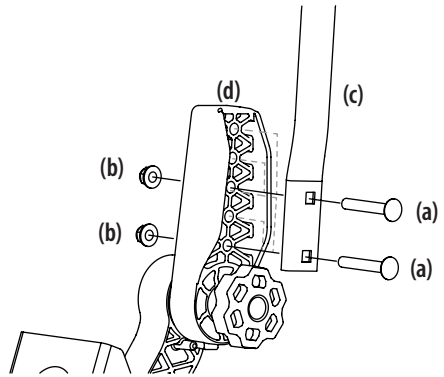

Figure 7

To adjust the lapbar drive control levers forward/rearward, proceed as follows:

1. Rotate the knob (a) counter-clockwise to loosen the knob (a). See Figure 8.
2. Lift and rotate the lapbar drive control lever into the desired position.
3. Rotate the knob clockwise to secure the lapbar drive control lever into position. See Figure 8.
4. If the lapbars do not line up after making the knob adjustment, loosen nuts (b), align lapbars and re-tighten nuts. Once this fine adjustment is made, the lapbars will align when using the knob adjustment. See Figure 7.

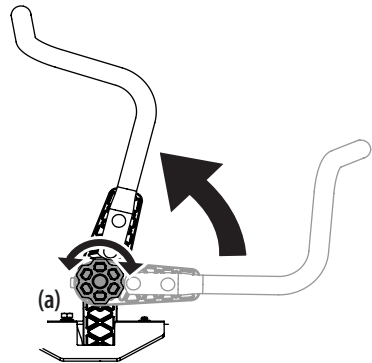

Figure 8

## Lower Discharge Chute Deflector

### ⚠ WARNING

Never operate the mower deck without the chute deflector installed and in the down position.

### ATTACHING THE CHUTE DEFLECTOR (IF NECESSARY)

1. Remove the keys attached with a zip tie to the chute bracket.
2. Remove the flange lock nut and hex screw from the deck.

# ASSEMBLY

- Place the chute deflector on the deck, be sure to insert the tabs on the chute deflector into the holes on the deck. See Figure 9.

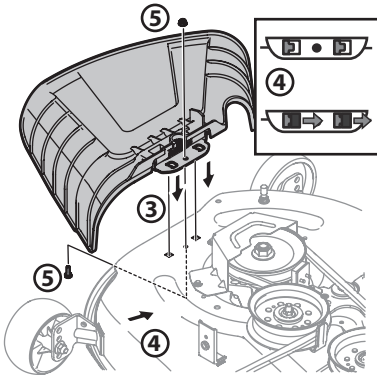

Figure 9

- Slide the chute deflector toward the rear of the tractor until the bolt hole in the chute deflector aligns with the hole in the deck. See Figure 9.
- Secure the chute deflector in place with the flange lock nut and hex screw removed in Step 2. Tighten to 102-124 in-lbs (11.5-14 N-m). Skip ahead to Setting Deck Wheels.

## REMOVING THE STOP BRACKET (IF NECESSARY)

- If the chute is shipped attached and with a stop bracket holding the chute upright, the stop brackets must be removed prior to operating the tractor.
- Holding the chute deflector fully upward, remove the stop bracket. Lower the chute deflector and discard the stop bracket. See Figure 10.

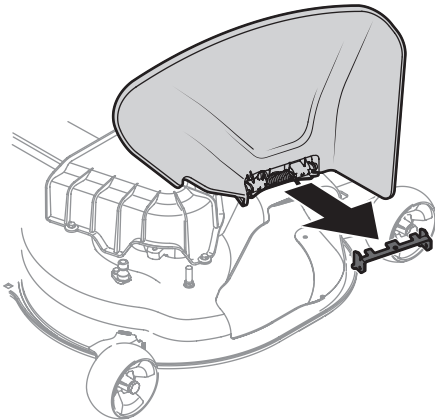

Figure 10

## Setting Deck Wheels (If Equipped)

**NOTE:** The deck wheels are an anti-scalp feature of the deck and are not designed to support the weight of the cutting deck.

- Move the tractor to a level surface, preferably pavement.
- Check tire pressure, adjust if necessary. See tire side wall for proper tire pressure.
- Make sure the deck is level side-to-side and properly pitched. See the Service and Maintenance section for deck leveling information and instructions.
- Place deck lift lever or knob in the desired mowing height position and lower deck.
- Check the wheels for contact or excessive clearance with the surface below.

**NOTE:** The deck wheels should have between 1/4" (6.35 mm) and 1/2" (12.7 mm) clearance above the ground.

- Remove the lock nut (a) gauge wheel (b) and shoulder screw (c) from the deck. See Figure 11.

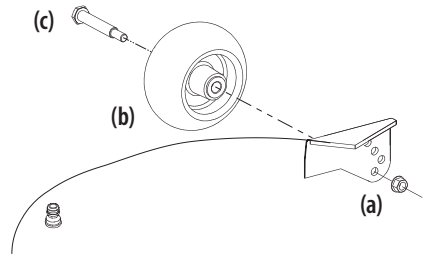

Figure 11

- Insert the shoulder screw into one of four index holes on deck wheel bracket. Allow a 1/4-1/2" (6.35-12.7 mm) clearance between the ground and gauge wheel.
- Note the index hole used on previously adjusted wheel. Repeat adjustment on opposite side to align both gauge wheels.

**NOTE:** Refer to Adjustments section of this manual for more detail.

## Battery Information

### ⚠ WARNING

**CALIFORNIA PROPOSITION 65 WARNING:** Battery posts, terminals and related accessories contain lead and lead compounds, chemicals known to the State of California to cause cancer and reproductive harm. Wash hands after handling.

# ASSEMBLY

## ⚠ WARNING

Should battery acid accidentally splatter into the eyes or onto the skin, rinse the affected area immediately with clean cold water. Seek prompt medical attention.

If acid spills on clothing, first dilute it with clean water, then neutralize with a solution of ammonia/water or baking soda/water.

**NEVER** connect (or disconnect) battery charger clips to the battery while the charger is turned on, as it can cause sparks.

Keep all sources of ignition (cigarettes, matches, lighters) away from the battery. The gas generated during charging can be combustible.

As a further precaution, only charge the battery in a well ventilated area.

Always shield eyes and protect skin and clothing when working near batteries.

Batteries contain sulfuric acid and may emit explosive gases. Use extreme caution when handling batteries. Keep batteries out of the reach of children.

## ⚠ CAUTION

When attaching battery cables, always connect the **POSITIVE (Red)** wire to terminal first, followed by the **NEGATIVE (Black)** wire.

**NOTE:** The positive battery terminal is marked Pos. (+). The negative battery terminal is marked Neg. (-).

## CONNECTING BATTERY CABLES

## ⚠ WARNING

Always connect the positive lead to the battery before connecting the negative lead. This will prevent sparking or possible injury from an electrical short caused by contacting the tractor body with tools being used to connect the cables.

For shipping reasons the factory may leave both battery cables disconnected from the terminals. To connect the battery cables, proceed as follows:

1. If present, remove the plastic cover from the positive battery terminal. Attach the red connector to the positive battery terminal (+) using the bolt (a) and hex nut (b). See Figure 12.
2. If present, remove the plastic cover from the negative battery terminal and attach the black cable to the negative battery terminal (-) with the bolt (a) and hex nut (b). See Figure 12.

3. Position the red rubber boot (c) over the positive battery terminal to help protect it from corrosion. See Figure 12.

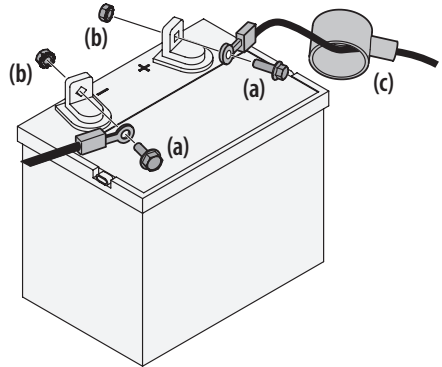

Figure 12

**NOTE:** If the battery is put into service after date shown on top/side of battery, charge the battery as instructed in the Service and Maintenance section, prior to operating.

## BATTERY MAINTENANCE

- The battery is filled with battery acid and then sealed at the factory. However, even a “maintenance free” battery requires some maintenance to ensure its proper life cycle.
- Spray the terminals and exposed wire with a battery terminal sealer or coat the terminals with a thin coat of grease or petroleum jelly, to protect against corrosion.
- Always keep the battery cables and terminals clean and free of corrosion.
- Avoid tipping. Even a sealed battery will leak electrolyte when tipped.

## BATTERY STORAGE

- When storing the tractor for extended periods, disconnect the negative battery cable. It is not necessary to remove the battery.
- All batteries discharge during storage. Keep the exterior of the battery clean, especially the top. A dirty battery will discharge more rapidly.
- The battery must be stored with a full charge. A discharged battery can freeze sooner than a charged battery. A fully charged battery will store longer in cold temperatures than hot.
- Recharge the battery before returning to service. Although the tractor may start, the engine charging system may not fully recharge the battery.